

# DIGITAL ABSOLUTE PLUS

## DIGITAL Active DUAL Technology BARRIER

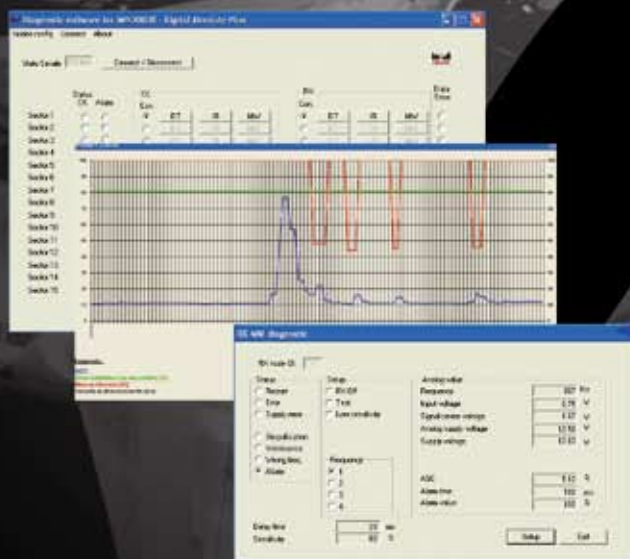

RANGE up  
to 200 mt.

**NEW...**  
REMOTE Configuration  
& Diagnostic  
Windows® based  
Interface BOARD



OUTDOOR PROTECTION  
OUR PROFESSION



MADE IN ITALY





## COMPANY PROFILE

### ✓ A SOLID REPUTATION

With a solid reputation based on more than 30 year's experience in the field, **SICURIT®** is one of the most reliable and technologically advanced companies in the security market, providing state-of-the-art outdoor perimeter solutions for any situation. The versatility of our product line together with our know-how and the experience of our engineers firmly places **SICURIT®** in this constantly growing market that expects the highest standards of quality combined with a world-class manufacturing infrastructure.

### ✓ DETAIL IN MANUFACTURING PROCESS

Our attention to detail in the manufacturing process, from the choice of raw materials to the rigorous tests carried out by our specialists and the comprehensive support provided by our staff, both pre-sale and after sale, have allowed us to win the trust of major players in the security market, from the USA to Australia, across all of Europe and parts of Asia.

### ✓ SICURIT A TRUSTED SUPPLIER

**SICURIT®** is a trusted supplier to many highly sensitive concerns, with our products deployed for the protection of civilian, industrial and military installations including airports, government compounds, financial institutions, electrical and nuclear facilities, military sites and correctional facilities.

### ✓ SICURIT HAS ACHIEVED ISO9001:2000 CERTIFICATION

**SICURIT® Alarmitalia Spa** has achieved **ISO9001:2000 certification**, the globally recognized quality standards that ensure the highest quality level of products and services within our organisation. In this way, we provide our customers with a totally reliable service that they can count on.





ABSOLUTE PLUS the unique dual technology barrier - www.sicurit.com - leading outdoor perimeter protections - ABSOLUTE PLUS the unique dual technology barrier

## OUTDOOR PERIMETER PROTECTIONS

### ✓ INTRODUCTION

Outdoor security systems detect intruders as soon as a protected area is entered and before intruders are able to gain access to people or valuable objects and assets. The sensors can be placed in clear zones, e.g. open fields, around buildings or along fence lines. Exterior sensors need to be resilient enough not only to withstand outdoor weather conditions, but also reliable enough to detect intrusion during harsh environmental conditions. Traditional and conventional exterior intrusion sensors have a lower probability of detecting intruders and a higher false alarm rate than their interior counterparts. This is due largely to many ungovernable factors such as: wind, rain, ice, standing water, blowing debris, random animals and human activity, as well as other sources including radio transmission interferences.

***These factors often require the use of two or more sensors to ensure an effective and safe intrusion detection screen.***

### ✓ THE SOLUTION

**Brand New Version ABSOLUTE PLUS** is a high security Dual Technology Barrier that combines Microwave and Infrared Technology to enhance capability of detection while drastically reducing false alarm rates (FAR).

Available in 3 ranges (200/80/50mt.), **ABSOLUTE PLUS** consists in a pair (TX and RX) of extruded aluminium columns in which Infrared Beam and Microwave Technology are combined into one unit; both sensing elements are located in a single casing, and are connected electronically using a special "AND" Logic Function. Since the two sensors will not detect an intrusion precisely at the same time the system has been designed to generate an alarm when both sensors produce an output in a pre-selected time interval.

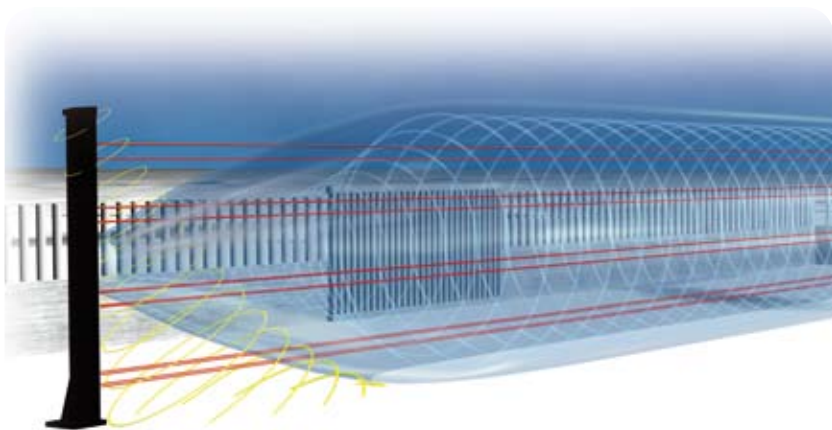

The sensors can be installed along a perimeter line, a fence or a delineated buffer zone, or as a defense against intruders approaching a gate or a wall. To further enhance the information performance, image/video recorder equipment can also be installed to survey the intrusion/approach zone. In addition to increase the detection potential this capability permits security personnel to assess the nature of the "intrusion/alarm" immediately and remotely.

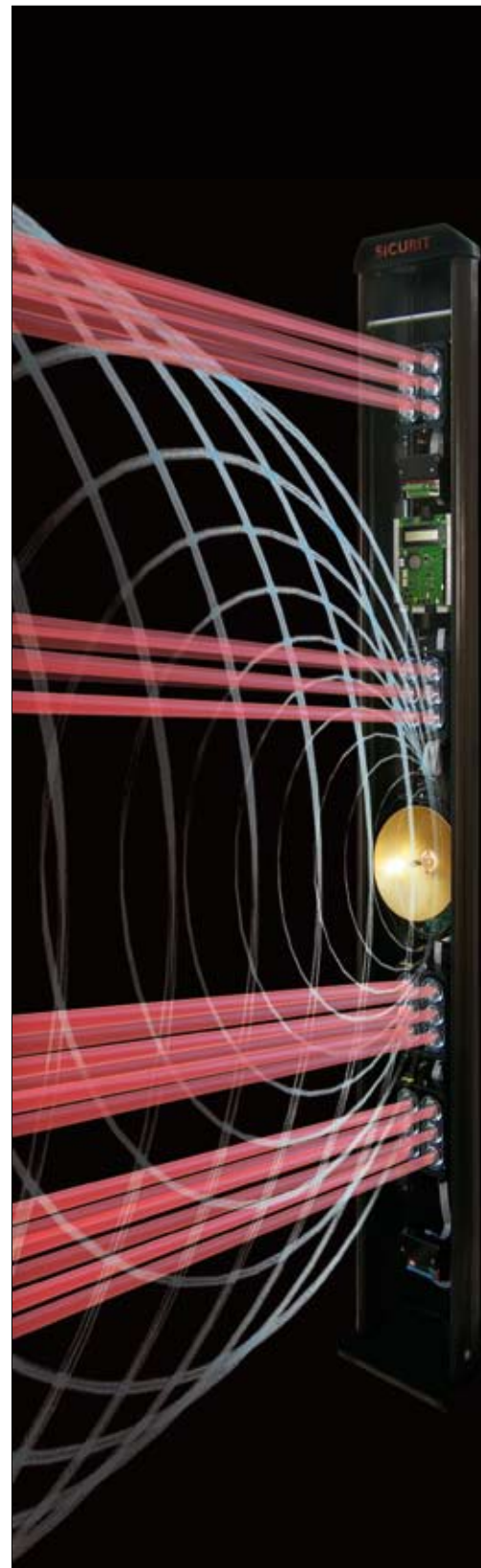



## METHOD of OPERATION and TECHNOLOGIES

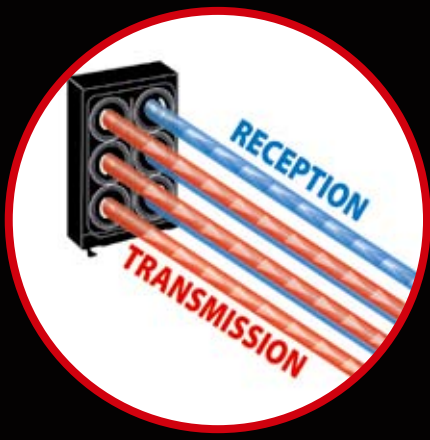

+  
**VIDEO**



### ✓ **MW and IR BEAMS FOR MAXIMUM CAPABILITY OF DETECTION**

**ABSOLUTE** is a combination of the two most common and reliable technologies used for outdoor applications: Active IR Beam and Microwave technology. The **ABSOLUTE PLUS** alarm is the result of a sophisticated combination of these two technologies.

Surveillance is carried out by a temporary window memory circuit. The pilot circuits of both detection systems are equipped with a timer whose range is adjustable from 20 seconds to 2 minutes. The first device (usually the Microwave, the activator) that receives a stimulus activates its own timer. Meanwhile, the second system is activated to confirm the final alarm. With this method of operation, nuisance alarms caused by environmental factors are completely eliminated.

### ✓ **TECHNOLOGY 1 : PATENTED INFRARED BEAMS**

The new SICURIT patented synchronised, codified and bi-directional Active Infrared Beams, main innovation in the new **ABSOLUTE PLUS** barrier, represent a clearly commitment in the advanced research and development of forefront technologies for perimeter security.

Peculiarity of the new IR Beams is the bi-directional code transmission via optics with random secure-codes. Each Optics Transmitter sends a continuously modulated Beam to the opposite Receiver which is tuned to recognize only its own signal: Once confirmed, the adjacent Optics (a Transmitter) will then send back to its receiver a new secure-code.

The bi-directional property of the system enable IR Beams to be totally immune to direct sunlight, often cause of nuisance alarms in traditional Infrared Beam Barriers.

IR Beams are also equipped with dedicated Relay contacts in case of disqualification, only to inform the security personnel that the system is working as a traditional system using only the Microwave Detector for the disqualification period.

The amount of IR Beams inside the column is determined by the height of the system and the application (high/medium security): **ABSOLUTE PLUS** is provided with 2 IR Beams default, but up to 8 Beams may be added to each system.

### ✓ **TECHNOLOGY 2 : The MICROWAVE**

The Microwave is the technology that functions as the "Activator" because, in most cases, it is activated first. Its detection capacity is determined by a lobe that can be regulated with its own trimmer, reaching up to 8 mt. in diameter.

Moreover, as an option, "anti-crawling" Doppler devices can be installed in case there are no Overlapping columns. This covers the blind area in proximity to the columns that the microwave's elliptical beam does not cover.

Planar Microwaves are used for models **IMN050** and **IMN080**

### ✓ **ADDITIONAL : ABSOLUTE PLUS VIDEO**

**ABSOLUTE PLUS** columns can be equipped with built-in CCTV cameras: the CCTV cameras are invisible and protected by a Plexiglas cover, and are, therefore, completely safe from atmospheric agents.

By connecting a Digital Video Recorder or a video transmission system via telephone lines, a time record of the alarm sequences can be obtained.

The **ABSOLUTE PLUS** video can also be integrated with the site's main CCTV system. By mounting a small camera inside the **ABSOLUTE PLUS**, pre-alarm pictures, when the alarm is triggered by the Microwave (usually the activator), can be stored.



ABSOLUTE PLUS the unique dual technology barrier - www.sicurit.com - leading outdoor perimeter protections - ABSOLUTE PLUS the unique dual technology barrier

## SYSTEM PHILOSOPHY

### ✓ NO MORE NUISANCE / FALSE ALARMS

IR Beam and Microwave technology can be affected by different environmental factors: ABSOLUTE PLUS system, as a result of its Dual Technology principle, is able to distinguish nuisance and false alarms as follows:

	Conventional IR beams	Conventional Microwaves	ABSOLUTE Dual Technology
SMALL BIRDS	FALSE ALARM	OK NO ALARM	OK NO ALARM
SMALL ANIMALS	FALSE ALARM	OK NO ALARM	OK NO ALARM
LEAVES PASSING BY THE WAY	FALSE ALARM	OK NO ALARM	OK NO ALARM
SUNLIGHT REFLECTIONS	FALSE ALARM	OK NO ALARM	OK NO ALARM
HIGH FREQUENCY SIGNALS	OK NO ALARM	FALSE ALARM	OK NO ALARM
FENCE SIGNAL REFLECTIONS	OK NO ALARM	FALSE ALARM	OK NO ALARM
FLUORESCENT LIGHTS	OK NO ALARM	FALSE ALARM	OK NO ALARM

False alarms are often caused by external, atmospheric conditions, or by the movements of animals.

The most frequent causes, as far as atmospheric conditions are concerned, are due to wind that causes movements of objects like pages of newspaper or plastic bags, which may interrupt the infrared beam.

As far as animals are concerned, the most frequent causes are due to the movements of stray dogs and cats or other wild animals, which can easily interrupt the infrared beams, especially those installed about 40 to 50 cm above the ground. Other causes of interruption of the beams installed at the top may be birds, which happens very frequently in open-field installations.

The built-in disqualifying circuits deactivate the IR Beams if a strong attenuation of the signal occurs caused by, for example, fog, heavy rain or heavy snowfall.

If the Infrared disqualification circuits start functioning, the sensitivity of the Microwave device decreases automatically (\*), and during this time span (of disqualification) the system functions using one only system (the Microwave).

### ✓ INTRUSION DETECTION UNDER HARD WEATHER CONDITIONS

	Infrared Beams Barrier	ABSOLUTE Dual Technology
FOG	ALARM DISQUALIFICATION	OK NO DISQUALIFICATION
HEAVY RAINS	ALARM DISQUALIFICATION	OK NO DISQUALIFICATION
HEAVY SNOW	ALARM DISQUALIFICATION	OK NO DISQUALIFICATION





## APPLICATIONS

### ✓ APPLICATION FIELDS

**ABSOLUTE PLUS** has been designed to protect outdoor sensitive areas like:

- Government buildings
- Airports
- Military sites
- Prisons
- Correctional facilities
- Nuclear plants
- Refineries
- Sensitive buildings and land areas
- Communications facilities
- Banking facilities
- Ports
- Museums
- Industrial & Commercial Sites
- Sites requiring maximum security.

### ✓ BASIC INSTALLATION RULES

The application of security measures is tailored to the needs and requirements of the facility to be secured. The security method adopted will be influenced by the type of facility or material to be protected, the nature of the environment and the client's previous security experience and any perceived threat.

There are many factors which need to be considered when planning a security system: the nature and time schedules of activities in and around the site or facility, the physical structure of the facility/complex to be secured, the surrounding natural and human environment, fluctuations and variations in the weather and the combination with new or proven technologies.

To use **ABSOLUTE PLUS**, it is fundamental that:

- There must be no physical obstructions between the Transmitter and Receiver columns, such as trees, bushes, or any solid structures that could interrupt the Infrared Beam communication.
- The ground has to be levelled (\*) to avoid the formation of "dead-zones" occurring between the lower Beam and the ground. If the ground is level, the gradient of the slope must not exceed the limit of the vertical adjustment of each component (approx. 15°C).

(\*) Sites can be protected even if the ground is not perfectly levelled; however, the level of security for those sites will be reduced due to the formation of dead zones.

### ✓ DEAD ZONES

To avoid "dead-zones" forming near Transmitters and Receivers due to the Microwave's cigar shape, it is important to overlap the barriers at each section to create a closed shield around the area to be protected. If this is not physically possible, special Anti-crawling Doppler units (**IME251**) are available to avoid un-protected sections.

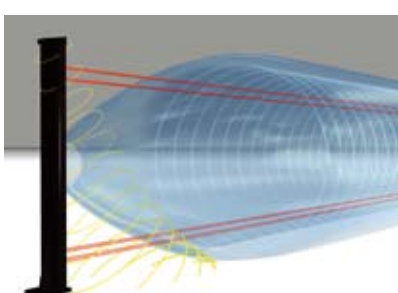



ABSOLUTE PLUS the unique dual technology barrier - [www.sicurit.com](http://www.sicurit.com) - leading outdoor perimeter protections - ABSOLUTE PLUS the unique dual technology barrier

## PRODUCT RANGE

### ✓ DIGITAL ABSOLUTE PLUS - RANGE 200 mt.

codes ▶	IMN200RS/2.0	IMN200RS/2.5	IMN200RS/3.0
Microwave	1 (default) to 2		
Infrared Beams	2 (default) to 8		
Column height	2,0 mt.	2,5 mt.	3,0 mt.
Range	200 mt.		

### ✓ ABSOLUTE PLUS - RANGE 200 mt.

codes ▶	IMN200/2.0	IMN200/2.5	IMN200/3.0
Microwave	1 (default) to 2		
Infrared Beams	2 (default) to 8		
Column height	2,0 mt.	2,5 mt.	3,0 mt.
Range	200 mt.		

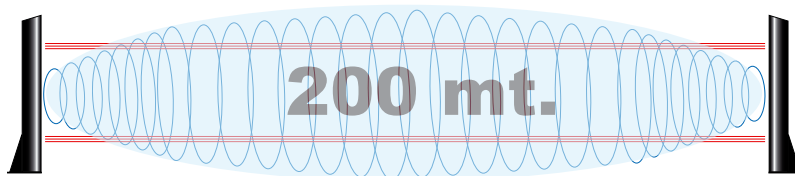

### ✓ MIDI ABSOLUTE PLUS - RANGE 80 mt.

codes ▶	IMN080/2.0	IMN080/2.5	IMN080/3.0
Microwave	1 (default) to 2		
Infrared Beams	2 (default) to 8		
Column height	2,0 mt.	2,5 mt.	3,0 mt.
Range	80 mt.		

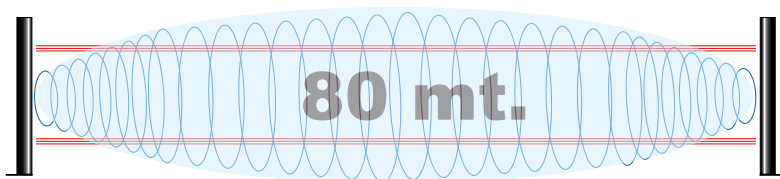

### ✓ MINI ABSOLUTE PLUS - RANGE 50 mt.

codes ▶	IMN050/2.0	IMN050/2.5	IMN050/3.0
Microwave	1 (default) to 2		
Infrared Beams	2 (default) to 8		
Column height	2,0 mt.	2,5 mt.	3,0 mt.
Range	50 mt.		

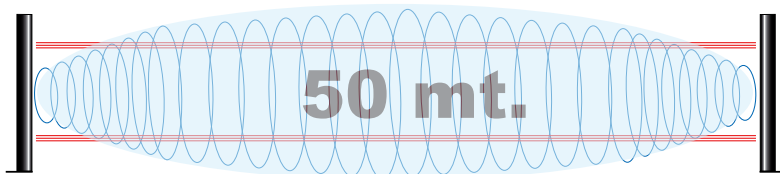

Standard ABSOLUTE PLUS - IMN200/2.0

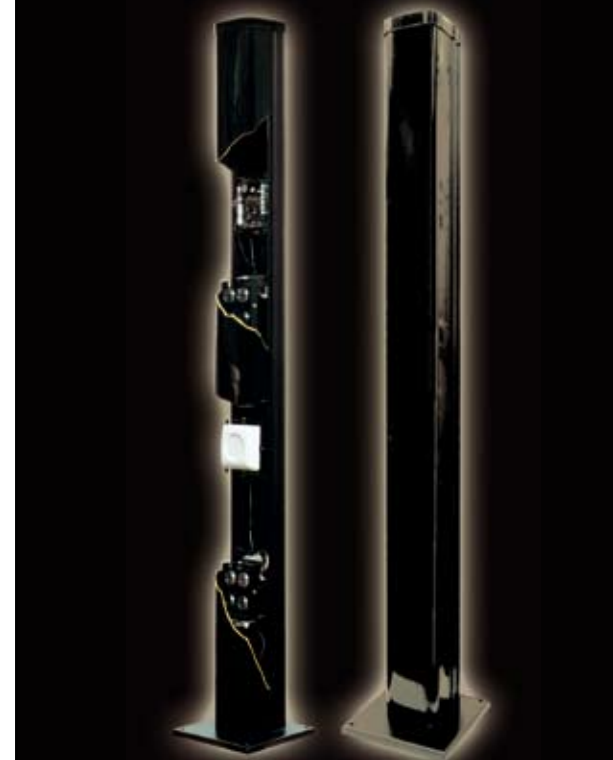

Standard MIDI and MINI ABSOLUTE PLUS



## New DIGITAL ABSOLUTE PLUS



### ✓ *IMN200RS - Digital ABSOLUTE Plus*

ABSOLUTE PLUS/RS is the new Digital Dual Technology Barrier with range of 200mt., a concentration of digital technologies to assure maximum protection while drastically reducing nuisance alarm rates due to uncontrollable environmental agents.

A state-of-the-art preassembled Barrier able to response to any site requirements with extremely flexible configurations, from its standard configuration that provide 2 IR Beams (6 Digital Lenses Bidirectional IR Beam Heads) and 1 Microwave (Digital Bi-static MW) in 2.00 mt. pillars improvable with up to 8 IR beams and 2 Microwaves lodged in 4.00mt. pillars for 200 meter full virtual protection.

### ✓ *IMN200RS - the easiest way to setup your ABSOLUTE barrier*

**Digital ABSOLUTE PLUS** Barrier is equipped with the new analysis board provided with a friendly user on-board alphanumeric **LCD display** which enables intuitive and easier parameter programming for the individual connected technologies, while allowing for the exact setting of installation parameters. (Default installation parameters are put into the memory during the production)

The LCD display furthermore avoids the installer the use of additional tools such as tester or dedicated tools. Furthermore, an integrated temperature sensor controls the resistance equipment to prevent fogging up, i.e. creation of dampness, condensate and dewiness inside the poles.

The board is equipped with standard outputs: Dual technology alarm output (free contact relay) with alternating floating contacts and a normally closed output for the tamper-protection circuit. Furthermore alarm information can be sent via **RS-485** to SICURIT remote interface board **IMNMBRD** (see page 9).

#### **DIGITAL ANALYSIS BOARD FEATURES**

- ❑ Alphanumeric display, size of 16 columns and 2 lines
- ❑ Check of barrier status (maintenance)
- ❑ Check of individual technologies status
- ❑ Configuration of barrier parameters from LCD display
- ❑ Remote configuration of barrier parameters (using **IMNMBRD** board)
- ❑ Alarm outputs with free contact relays
- ❑ Synchronization connection between poles for high system performance
- ❑ By-pass of lowest IR optics
- ❑ Buzzer for the sound signalling of individual technologies alarms or general signalling
- ❑ Signalling by means of **BEA1224ALI** (built-in power supply) of fuse failure, main power failure and/or low battery
- ❑ Programmable time alarm windows of each technology





DIGITAL ABSOLUTE PLUS the unique dual technology barrier - www.sicurit.com - leading outdoor perimeter protections - DIGITAL ABSOLUTE PLUS

## New DIGITAL ABSOLUTE PLUS



✓ **IMNMBRD - Control up to 15 pair of barriers**

The additional remote interface board **IMNMBRD**, that includes a friendly-user **Windows®** based software, is able to link up to 15 barriers (15Tx + 15Rx) for remote configuration and diagnostic and easier integration into any management software.



- RS-485
- Relay Output
- RS-232
- Syncro cable

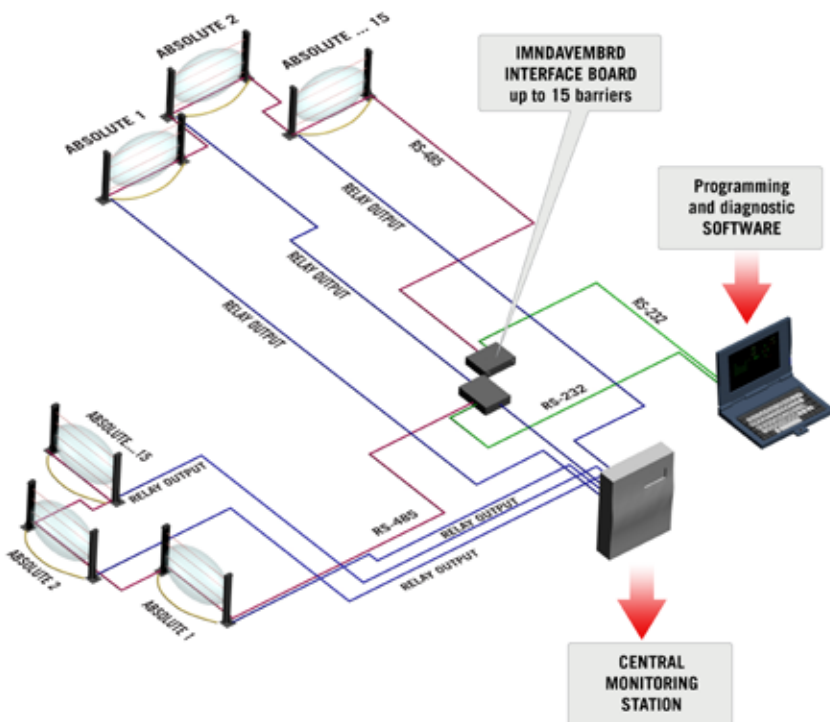

### IMNMBRD MAIN FEATURES

- ❑ Configuration and diagnostic Windows® based Software (included)
- ❑ Setup of each single unit
- ❑ Event LOG with graphic representation of alarms
- ❑ Upgradable by optional expansion boards to meet site configuration
- ❑ Input and output functions selectable
- ❑ Up to 64 input/output selectable
- ❑ Up to 4 RS-485 serial port available
- ❑ RS-232 or USB connection to PC
- ❑ Connection to any kind of control system, control unit and easy hardware-software integration
- ❑ Easy barrier maintenance by Software
- ❑ Stored data analysis

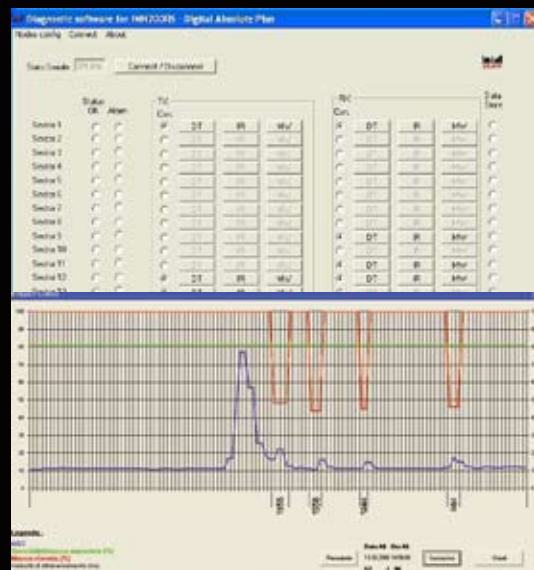

### CONFIGURATIONS

Basic (Rack case of 1U – 19")

- ❑ 1 RS-485 serial
- ❑ 8 functional input
- ❑ 8 Open Collector output for analysis
- ❑ 1 serial RS-232 or USB for PC connection
- ❑ Programming and Diagnostic Software

Expansion Set

- ❑ Up to 4 RS-485 serials, to split the installation on 4 RS-485 lines of 1Km each.
- ❑ Up to 64 functional Input or Output O.C. selectable in groups of 16



## ACCESSORIES

To complete and upgrade ABSOLUTE PLUS system, option devices are available:

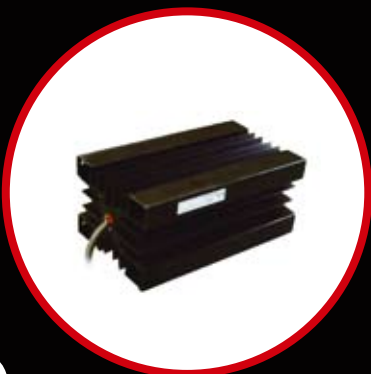
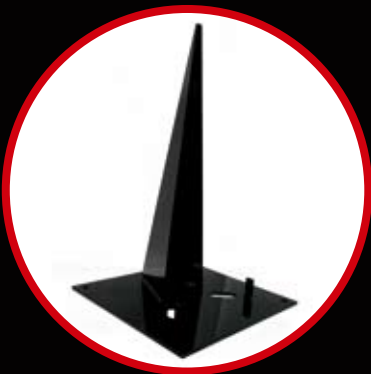

Codes	Pictures	Description
<b>IMN242</b> <i>additional IR Beam</i>		ABSOLUTE PLUS is supplied in with 1 Microwave and 2 IR beams default. This configuration is suitable for car pounds or sites where large objects need to be detected. To protect against highly trained intruders, a higher security level is recommended by adding additional IR beams (up to 8 in its maximum configuration).
<b>IME207/IME208</b> <i>bases</i>		If the ABSOLUTE system needs to be mounted directly onto any type of flat surface, two different bases are available depending on the height of the pillars. If the pillar height exceeds 2.00 metres, a reinforced base (IME208) is highly recommended.
<b>BEA1224ALI</b> <i>power supply</i>		It can be driven by a 230VAC source: it supplies two different voltage outputs (12VDC/24VAC) providing a complete service to each barrier (system and anti-haze resistor). This power-supply has to be used with a 12V 7AH battery back-up.
<b>IMN246/IMN247</b> <i>Maintenance board</i>		It provides additional information on the status of the system. This board provides 8 O.C. alarm outputs (for each IR beam) and 8 O.C. for disqualification outputs. To be used only for system maintenance.
<b>IME251</b> <i>doppler microwave</i>		Special Doppler devices are available if ABSOLUTE columns can not be overlapped, e.g. single system installation.
<b>IMERES</b> <i>PTC heater</i>		Every electronic component mounted inside the ABSOLUTE is provided with a thermostat heater to guarantee that it works efficiently even at very low temperatures (up to -20°C). For lower temperatures a special PTC heater (IMERES) is available to increase the internal airflow (tested up to -40°C).
<b>Brackets</b> : Additional brackets are available to fit cameras, power-supplies or batteries		
<b>BEC031</b>		Support for Power Supply
<b>BEC032</b>		Support for Battery
<b>IME206</b>		Bracket for camera mounting
<b>Only for DIGITAL ABSOLUTE PLUS series</b>		
<b>IMNMBRD</b> <i>remote interface board</i>		Additional remote interface board with a friendly-user <b>Windows</b> ® based software, allows to control up to 15 barriers for remote configuration and diagnostic.



ABSOLUTE PLUS the unique dual technology barrier - [www.sicurit.com](http://www.sicurit.com) - leading outdoor perimeter protections - ABSOLUTE PLUS the unique dual technology barrier

## TECHNICAL FEATURES

Model (code)	IMN200RS	IMN200	IMN080	IMN050
RANGE	200 mt.		80 mt.	50 mt.
HEIGHTS	2,0 mt. - 4,0 mt.			
NUMBER OF MICROWAVES	1			
NUMBER OF BEAMS	2 (up to 8)			
BEAM HEADS HORIZONTAL MOVEMENT	+ / -20°			
BEAM HEADS VERTICAL MOVEMENT	+ / -10°			
OPERATING VOLTAGE	12VDC and 24VAC, AC heater system			
TYPICAL POWER 12VDC CONSUMPTION	800mA	510mA		
TYPICAL POWER 24VAC CONSUMPTION	860mA			
MAXIMUM POWER CONSUMPTION (8 IR)	1050mA	850mA		
OPERATING TEMPERATURE RANGE	-25° + 65°C			
OPERATING TEMPERATURE RANGE with IMERES device	-40° + 65°C			
ALARM OUTPUTS	CONTACT RELAY and/or RS-485	FREE CONTACT RELAY		
MOUNTING	SURFACE			
HOUSING	IP55			
CONSTRUCTION	ALUMINIUM EXTRUSION			
COLUMN DIMENSIONS	260 x 145 x (H) mm. (W x D x H)		166 x 155 x (H) mm. (W x D x H)	
BASE DIMENSIONS	400 x 400 mm. (W x D)		280 x 280 mm. (W x D)	
<b>MICROWAVE FEATURES</b>				
FREQUENCY	9.9 GHz. / or according to national regulations			
LOBE DIAMETER	from 2 mt. to 8 mt.			
NUMBER OF CHANNELS	4			
<b>IR BEAM FEATURES</b>				
OPTICS	6 Lenses (3 TX + 3 RX)			
WAVE LENGTH	940nm (pulse code)			
SAMPLING TIME BEAM	from 40 to 500mS			
MAXIMUM BEAM CONFIGURATION	8 beams			

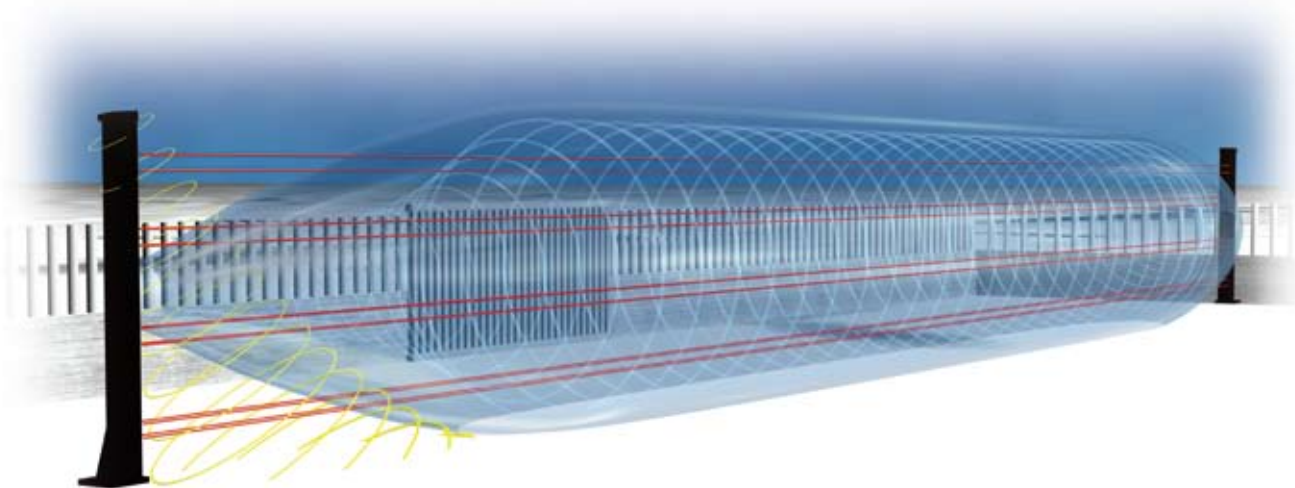



ABSOLUTE PLUS the unique dual technology barrier - [www.sicurit.com](http://www.sicurit.com) - leading outdoor perimeter protections - ABSOLUTE PLUS the unique dual technology barrier

## REFERENCE LIST

### ITALY

- Pharmaceutical companies
- R&D facilities
- Electrical utilities
- Car pounds
- Military installations
- Correctional facilities
- Banking facilities
- Manufacturing plants
- Sensitive buildings and land areas
- Others

### USA

- Banking facilities
- Governmental Buildings
- Correctional Facilities
- Electrical Utilities
- Universities
- Others

### CZECH REPUBLIC

- Military installations
- Electrical Utilities
- Airports
- Others

### SLOVAKIA

- Correctional Facilities
- Electrical Utilities

### BELGIUM

- Correctional facilities

### HONG KONG

- Correctional Facilities

### CHINA

- Nuclear power plants
- Museums

### AUSTRALIA

- Prisons

### MOROCCO

- Petrol stations

### FRANCE

- Prisons

### SWEDEN

- Nuclear Power Plants

### POLAND

- VIP residences

### DENMARK

- Governmental Buildings

### SPAIN

- Water plants
- Army depots

### KUWAIT

- Governmental Buildings

### SOUTH KOREA

- Nuclear Power Plants

... & more

## CONTACTS

**EUROPE**  
Headquarter

**SICURIT Alarmitalia Spa**  
Via Gadames, 91  
20151 - Milan - Italy  
Tel.: +39.2.38070.1  
Fax: +39.2.308.80.67  
Website: [www.sicurit.com](http://www.sicurit.com)  
E-mail: [export@sicurit.it](mailto:export@sicurit.it)

**PACIFIC ASIA**  
Subsidiary

**SICURIT China**  
8D Ganlan Pengyuan,  
1# Caitian RD,  
SHENZHEN - China  
Tel.: +86.755.828.67759  
Fax: +86.755.828.67761  
E-mail: [info@sicurit.cn](mailto:info@sicurit.cn)

**U.S.A.**  
Exclusive Distributor

**SAFEGUARDS TECHNOLOGY**  
75 Atlantic street  
NJ 07601 Hackensack  
Tel.: 201.488.1022  
Fax: 201.488.1244  
Website: [www.safeguards.com](http://www.safeguards.com)  
E-mail: [marketing@safeguards.com](mailto:marketing@safeguards.com)